

# Taking a compass bearing

By Owen Michael

# Step 1

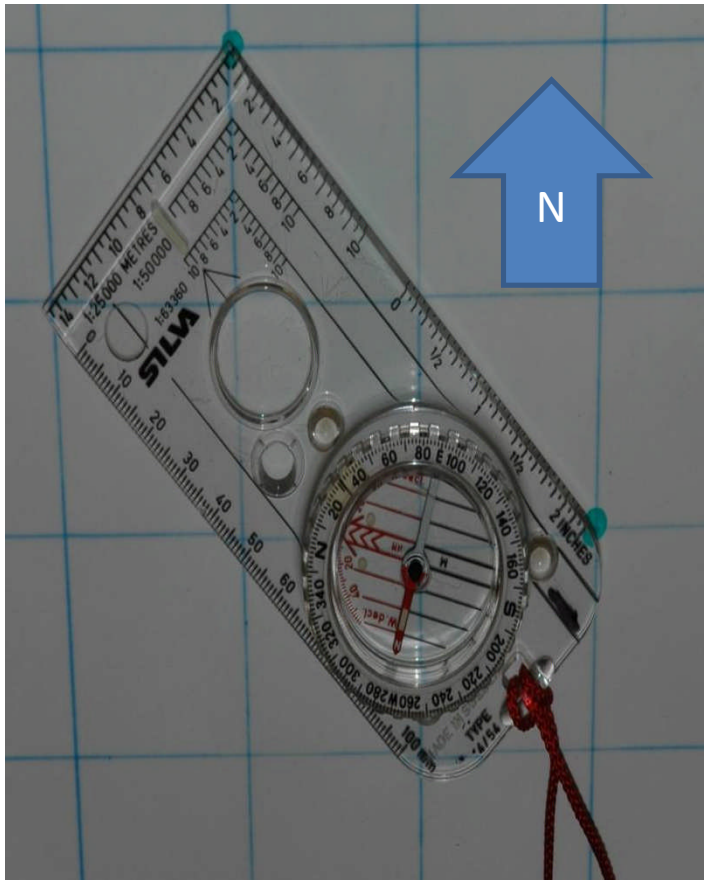

Put the compass along the path between the two points (between where you are and where you are going).

## Step 2

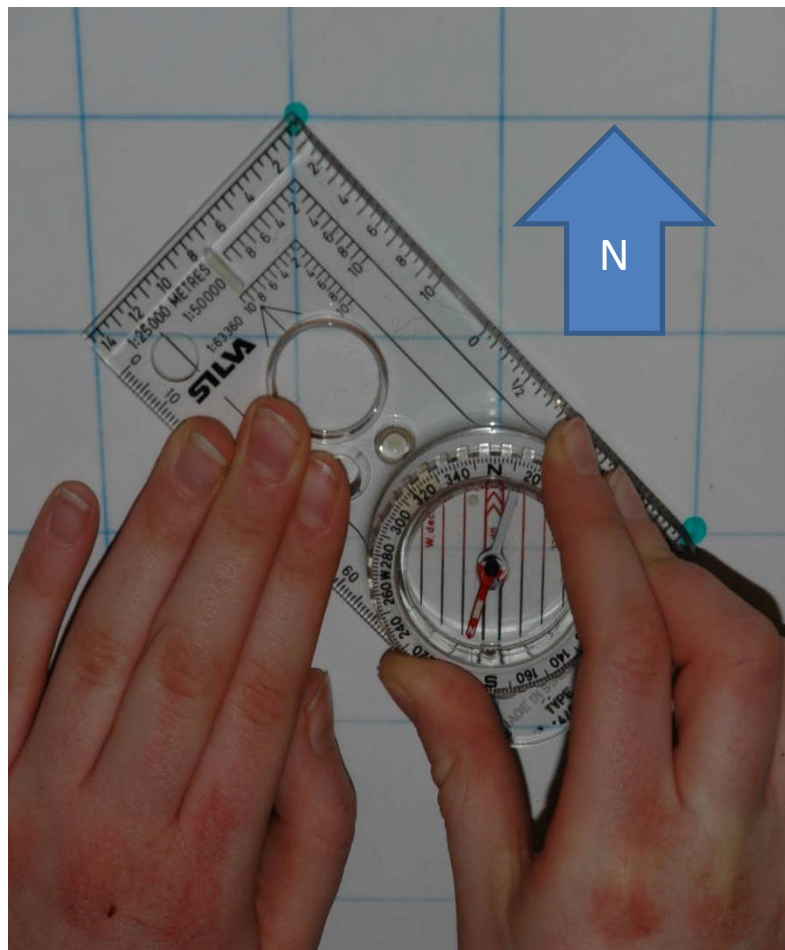

Make sure that the black lines are parallel with the vertical lines on the map with the red arrow on the base pointing north on the map.

# Step 3

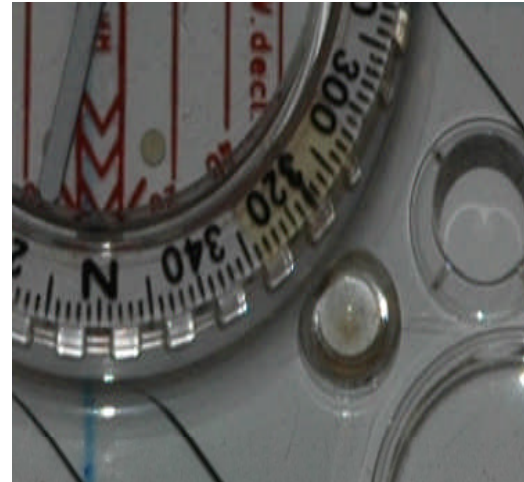
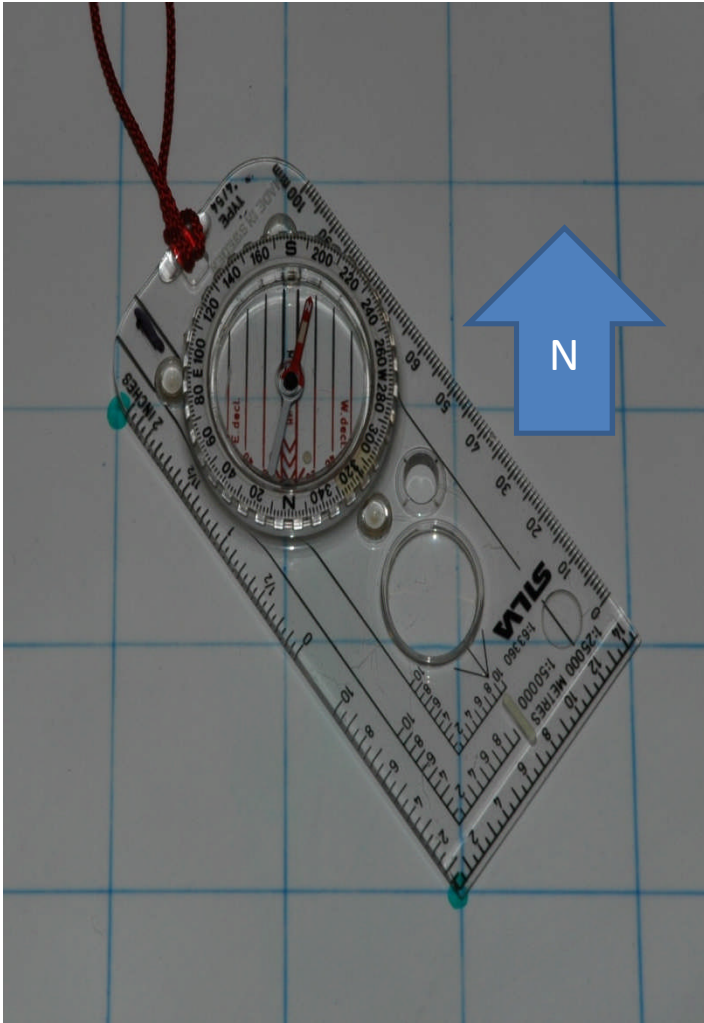

Look at the bearing (the number in the yellow section of the dial [circle]) in this case the bearing is 316°.

# Step 4

Turn around until the compass needle aligns with the red arrow on the base and walk forward in the direction you're facing in.

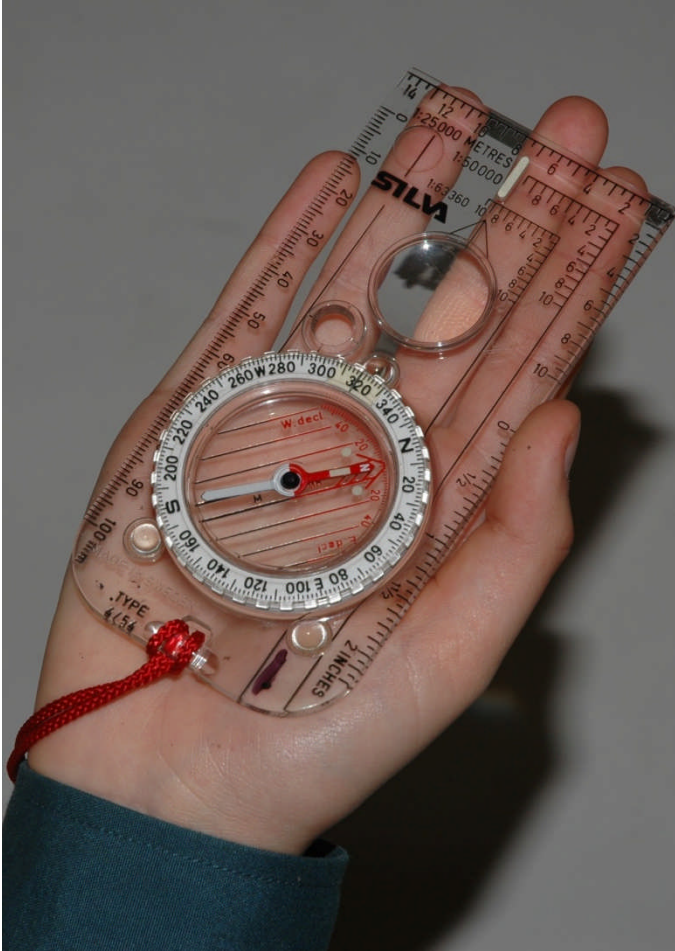

Advisor-Owen Michael

Demonstrator-Owen Michael

Writer-Owen Michael & Jake Bruce

Assistant- Jake Bruce

Courtesy of 67<sup>th</sup>'s laptop